

## Tubing » Films » Tiles



127

TUBING » FILMS » TILES

Totally practice-oriented: BOLA Tubing, Films and Tiles meet the highest demands and are used in more and more laboratories.

### PRODUCT TIPS



Page 136:  
PTFE Tubing



Page 132:  
Flexible Tubing



Page 133:  
Conductive Tubing

# BOLA Tubing



## BOLA Tubing offers many advantages:

- » **Short minimum lengths**  
Depending on the tubing dimensions – for details please look at our price-list. Minimum lengths are unfortunately necessary for granting a low price per metre.
- » **No specification of fixed rolls – available per metre**  
Free choice of requested length between minimum length and maximum production length
- » **Longer lengths in one piece possible**  
For tubing up to O.D. 10 mm, quantities of up to 100 metres in one length are possible without extra charge; quantities of more than 100 metres in one length are only available in particular cases – please ask us.
- » **Whenever possible, your ordered quantity is supplied in one length**  
If our inventory or the ordered quantity does not allow another possibility, the tubing is supplied in partial lengths without consultation. Example: 90 m = 60 m + 30 m
- » **Good to handle**  
Tubing up to an O.D. of 3 mm and with a minimum length of 30 m is supplied on reels. This prevents bends and twists and makes storage and rolling up easier.
- » **Tailored rolls/reels are available**  
Several rolls with the same lengths are available at low extra charges, e.g. 5 rolls of 40 metres or 11 rolls of 22 metres.
- » **Excellent quality at fair prices**  
Stricter tolerances than the general industrial standard GKV – perfect interaction with our BOLA Fittings and BOLA Stopcocks

## Tolerances of BOLA Tubing – You can count on them.

BOLA Tubing is perfectly suitable for the use with all BOLA Screw Joint Systems. You can be sure that all fittings and screw joints fit together with the tubing. The production of tubing always involves certain tolerances in outer diameter and wall thickness.

We always check our tubing repeatedly on the basis of strict BOLA-internal standards. These standards are stricter than the standards which are currently in the market.

- Nominal O.D.  
from 0,4 mm to 3,2 mm  
» tolerance of O.D. +/- 0,05 mm
- over 3,3 mm to 10,0 mm  
» tolerance of O.D. +/- 0,10 mm
- over 10,1 mm to 16,0 mm  
» tolerance of O.D. +/- 0,15 mm
- over 16,1 mm to 22,0 mm  
» tolerance of O.D. +/- 0,20 mm
- over 22,1 mm  
» tolerance of O.D. +/- 0,25 mm



**HELPFUL:** page 248  
Detailed information about  
tubing tolerances

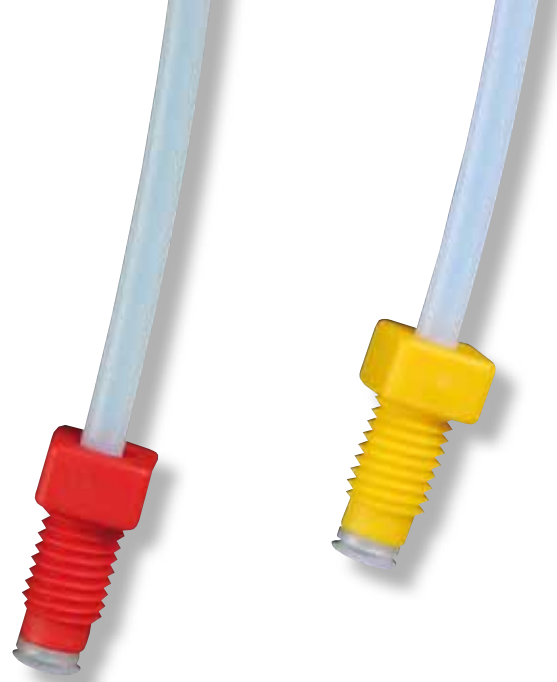

**What you should know about the choice of tubing**

Incorrectly chosen tubing can endanger the user. Here you can find the most important features in tabular form. The number of "+"-signs stands for the degree of performance of the feature.

Tubing material	PTFE	PFA	FEP
Maximum temperature <small>(at moderate charge)</small>	+260°C	+260°C	+205°C
Minimum temperature <small>(at moderate charge)</small>	-200°C	-270°C	-270°C
Chemical resistance	+++	+++	++(+)
Transparency	+	++(+)	+++
Surface quality	++	+++	+++
Gas proofness <small>(in limit range)</small>	++	+++	+++
Recovery	+	++	++
Costs	+	+++	++

Our tip: PTFE tubing is ideal for the "normal" work in laboratories.

If you need tubing which is absolutely gastight even in limit range of pressure and temperature, you should choose PFA or FEP. PFA only has advantages at temperatures of more than +205°C, but is more expensive than FEP tubing.

**We shape and bend ... according to your needs.**

FEP and PFA tubing is most suitable for shaping or bending. A special thermal procedure is applied to shape the tubing to the requested form. Please contact us for a free and non-binding quotation.

**We connect and assemble ... according to your needs.**

We can offer you our "know how" for cutting tubing, assembling fittings (either from our standard range or suitable for your specific system) from single pieces to complete series manufacturing. Please contact us for a free quotation.

**Typical range of applications for tubing made of fluoroplastics (PTFE, PFA, FEP)**

- » For transport of aggressive products such as acids, lyes, gases and solvents
- » For analysis- or measuring devices of chromatography and laboratory
- » As product lines in miniplant systems
- » As dosing lines for reaction vessels
- » In liquid chromatography; high-purity tubing without additives (e.g. softeners) which could destroy analysis
- » As covering of mechanically operated parts, e.g. bowden wires (due to the low coefficient of friction)
- » As covering of sensors in chemical plants
- » For transport of lacquers, oils, resins and food products
- » As covering of heating elements in galvanic stations and microelectronics
- » Antistatic tubing in explosive applications

# BOLA Tubing



## Frequently asked questions about customized tubing

### » Which tubing dimensions are available?

We can supply tubing with outer diameters between 0,4 mm and 40 mm and wall thicknesses between 0,1 mm and 4 mm.

### » What if I only need a small quantity of customized tubing?

Small quantities can be supplied but only at higher cost as a minimum order quantity has to be purchased. Unfortunately it is not possible to indicate exact minimum lengths. In general: the smaller the outer diameter, the bigger the minimum quantity and the smaller the price per metre. Please send us your actual requirement. We will then provide you with the corresponding minimum quantity and price.

### » Which tubing materials do you offer?

We offer tubing made of fluoroplastics such as PTFE, PTFE-EX, FEP and PFA. Additionally, we supply tubing made of PEEK.

### » What shall I do if I am not sure if the requested tubing is producible?

Normally we know this and can inform you quickly.

### » Do you have screw joint systems for every diameter of tubing?

We offer a wide range of screw joints. A screw joint system to your requirements might already exist. If not, custom screw joints can be offered and supplied. Please contact us.

### » How do close tolerances affect the price of tubing?

In general, close tolerances increase the price for production because expenses for checking the tubing are higher and there can be more waste of tubing which does not fulfil these close tolerances. It can even occur that a production is not possible if the tolerances are too close – in this case we will contact you to find a solution.

### » What is the lead time for tubing?

The lead time depends on many factors such as dimension, quantity, material, tolerances and running length. The typical lead time for customized tubing is between 3 and 6 weeks.

### » How do I get a quotation?

Send us your enquiry by fax or e-mail stating all relevant dimensions such as diameter, length, etc. We will do our utmost to get our offer to you as soon as possible. Please do not forget to indicate the required quantity. It is also important to include in your enquiry whether the requested tubing is a one-time or a repeating need.



### Cleaning and reuse of tubing

In general, cleaned fluoroplastic tubing should only be reused if the transported product is known and rated with “+” in the chemical resistance chart (page 237).

It is not recommended to reuse the tubing with unknown products and mixtures of chemicals. For all water-soluble substances (e.g. salts, acids, bases etc) you can use water as cleaning agent.

Volatile solvents such as alcohols, esters, ketones, low-boiling hydrocarbons, chlorinated hydrocarbons are given off reversibly by storing under aeration (only if they have not been absorbed by the interior surface of the tubing).

If you are using substances which can only be eliminated by organic solvents or if you are using toxic and dangerous products, the tubing should be disposed appropriately after use. A visual inspection or, in case of unclarity an inspection according to EN 12115, has to be made before reusing cleaned tubing.

### You haven't found anything suitable? – No problem

**We would be glad to send you a quotation. For quick processing, we need some information:**

- » Outer diameter in mm (e.g. 16 mm)
- » Inner diameter in mm (e.g. 12 mm)
- » Which quantity in one length do you need?
- » Which total quantity do you need?
- » Which material shall be used?

### Further information – not obligatory, but often making sense.

- » Do you need special tolerances for outer or inner diameter (e.g.  $\varnothing$  10 mm +/- 0,1 mm; this means tubing can vary between 9,9 mm and 10,1 mm)?
- » Shall the tubing be deformable, for example for making flanges?
- » Up to which temperature will the tubing be used?
- » Which pressure shall the tubing resist?
- » Shall the tubing be electroconductive?
- » Shall the tubing be transparent?
- » Shall the tubing have a special surface quality?
- » Do you need certificates? (e.g. test certificates, certificates of compliance or FDA certificates)
- » To which pressure or vacuum at which temperatures is the tubing exposed?
- » Do you need special packaging?
- » Shall the tubing be dyed with a colour? Which colour do you request?
- » Do you need an exceptionally tight bending radius?
- » Does the tubing have to be absolutely gastight?



**BESTSELLER**

## BOLA Flexible Tubing

Material: **PFA**    Temperature resistance: **from -270°C to +260°C**    Chemical resistance: **+++ universal**    Transparency: **transparent**    Vacuum: **suitable**

### Product description:

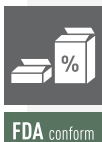
Corrugated tubing with circular corrugations around the longitudinal axis and cylindrical tubing ends with a length of 40 mm which can for example be connected directly to fittings, stopcocks or hose connectors. Together with BOLA Laboratory Screw Joints, the connection is absolutely tight and suitable for vacuum.



FDA conform

Tubing size NW	Tubing end I.D.	Tubing end O.D.	Bending radius <sup>1</sup> mm	Pressure load max. bar	Length 0,25 m Cat. No.:	Length 0,5 m Cat. No.:	Length 1,0 m Cat. No.:	Length 2,5 m Cat. No.:
4,5	2	4	5	1,7		S 1822-01	S 1822-19	S 1822-52
8	6	8	15	2	S 1822-92	S 1822-02	S 1822-20	S 1822-56
10	8	10	18	2	S 1822-93	S 1822-04	S 1822-22	S 1822-60
13	10	12	23	2	S 1822-94	S 1822-06	S 1822-24	S 1822-64
14	12	14	25	2		S 1822-08	S 1822-26	S 1822-68
16	14	16	28	2		S 1822-10	S 1822-28	S 1822-72
19	16	18	32	2	S 1822-98	S 1822-14	S 1822-32	S 1822-76
21	17,5	20	35	2		S 1822-16	S 1822-34	S 1822-80
23	20,9 (1")	25,4	40	1,2		S 1822-18	S 1822-36	S 1822-84



**SUITABLE:** page 67  
Laboratory screw joints

### Product advantages:

- » flexible to highly flexible
- » tight bending radius only causes little cross-section reduction
- » non-porous
- » translucent

### Applications:

- » ideal for connections under vibrations
- » usable with a small bending radius
- » for compensation of thermal expansions
- » for easy handling of liquids

« Special Request? »  
+49 (0) 93 46-92 86-0

## BOLA Customized Flexible Tubing

Flexible tubing made of PFA can be manufactured individually according to your specifications. We would be glad to send you a quotation.

**Please complete the list below and send us a copy by fax to +49 (0)9346-928651. Thank you.**

Quantity:	
Tubing size NW:	
<b>A</b> Tubing end length:	
<b>B</b> Tubing end length:	
<b>C</b> Total length:	
<b>D</b> Tubing end I. D.:	
<b>E</b> Tubing end O.D.:	

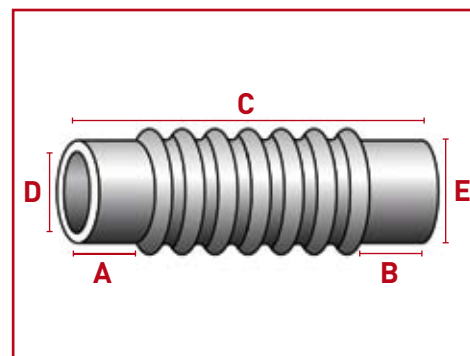

<sup>1</sup> Bending radius: minimum bending radius in mm at a room temperature of 23°C



## BOLA Flexible Tubing Ex

Material: PFA-EX    Temperature resistance: from -270°C to +260°C    Chemical resistance: +++ universal    Conductivity: 10<sup>5</sup> Ohm

### Product description:

Conductive corrugated tubing with nominal width 10 and with circular corrugations around the longitudinal axis. Cylindrical tubing ends with a length of 40 mm can for example be connected directly to fittings, stopcocks or hose connectors. Together with BOLA Laboratory Screw Joints EX, the connection is conductive, absolutely tight and suitable for vacuum.

**NEW**

Tubing end		Bending radius <sup>1</sup> mm	Burst pressure <sup>2</sup> bar	Length 0,5 m Cat. No.:	Length 1,0 m Cat. No.:	Length 2,5 m Cat. No.:
I.D.	O.D.					
4	6	18	13	S 1824-24	S 1824-54	S 1824-74
6	8	18	13	S 1824-27	S 1824-57	S 1824-77
8	10	18	13	S 1824-30	S 1824-60	S 1824-80
10	12	18	13	S 1824-33	S 1824-63	S 1824-83

### Product advantages:

- » conductive with surface resistance of 10<sup>5</sup> Ohm
- » flexible to highly flexible
- » tight bending radius only causes little cross-section reduction
- » non-porous

### Applications:

- » antistatic applications
- » in explosive ambiance (explosion protection)
- » for easy handling of liquids and gases
- » for transport of solvents or alcohols
- » ideal for connections under vibrations
- » usable with a small bending radius
- » for compensation of thermal expansions



**SUITABLE:** page 110  
Conductive fittings and stopcocks  
made of PTFE -Ex



<sup>1</sup> Bending radius: minimum bending radius in mm at a room temperature of 23°C

<sup>2</sup> Burst pressure: computed value in bar at a room temperature of 23°C. It is recommended to restrict the maximum working pressure to 25% of the burst pressure. For higher temperatures, this value has to be multiplied by the reduction factor shown on page 244. It is the user's responsibility to check if the used tubing fulfils the respective requirements.

**Hotline +49 (0) 93 46-92 86-0**



## BOLA BENEFITS

- » extensive chemical resistance due to PTFE parts
- » resistance of less than  $10^6$  Ohm according to EN 12115 directive
- » ideal for light-sensitive substances

### BOLA Antistatic Explosion-Proof Tubing

**BESTSELLER**

Material: PTFE-EX    Temperature resistance: from -270°C to +260°C    Chemical resistance: +++ universal    Conductivity:  $10^6$  Ohm

#### Product description:

Very good electric conductivity due to a special "antistatic compound" made of pure PTFE and finest, highly pure carbon dust (less than 2,5%).  
Colour: black

**NEW**
**FDA conform**

I.D. mm	O.D. mm	Wall thickness mm	Bending radius <sup>1</sup> mm	Burst pressure <sup>2</sup> bar	Cat. No.:
(1/32") 0,8	(1/16") 1,6	0,4	7	140	S 1827-10
(1/16") 1,6	(1/8") 3,2	0,8	13	140	S 1827-26
2,0	3,0	0,5	18	70	S 1827-30
4,0	6,0	1,0	36	70	S 1827-40
6,0	8,0	1,0	64	46	S 1827-50
8,0	10,0	1,0	100	35	S 1827-60
10,0	12,0	1,0	144	28	S 1827-64
12,0	14,0	1,0	196	23	S 1827-68

#### Applications:

- » antistatic applications
- » in explosive ambience (explosion protection)
- » for transport of solvents or alcohols

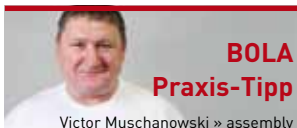

### BOLA Praxis-Tipp

Victor Muschanowski » assembly

#### Easy tubing assembly:

Before assembling the tubing on a hose connector, heat it in an oven or with a hot air gun to approx. 60°C. All BOLA products can be heated for easier assembly or disassembly

<sup>1</sup> Bending radius: minimum bending radius in mm at a room temperature of 23°C

<sup>2</sup> Burst pressure: computed value in bar at a room temperature of 23°C. It is recommended to restrict the maximum working pressure to 25% of the burst pressure. For higher temperatures, this value has to be multiplied by the reduction factor shown on page 244. It is the user's responsibility to check if the used tubing fulfils the respective requirements.





## BOLA BENEFITS

- » the flowing product is only exposed to PFA
- » no chemical restrictions due to the outer conducting stripes
- » resistance less than  $10^6$  Ohm
- » smooth, non-porous interior surface
- » clear visibility of the flowing product
- » no corrosion unlike metal lines or metal meshes
- » almost universal chemical resistance

### BOLA Zebra Explosion-Proof Tubing

**BESTSELLER**

Material: PFA-EX    Temperature resistance: from -270°C to +250°C    Chemical resistance: +++ universal    Conductivity:  $10^6$  Ohm

Product description:

Transparent PFA tubing with black longitudinal conductive stripes on the outer surface. The tubing is absolutely round and can be connected to all common fittings.

**NEW**

FDA conform

I.D. mm	O.D. mm	Wall thickness mm	Bending radius <sup>1</sup> mm	Burst pressure <sup>2</sup> bar	Cat. No.:
2,0	3,0	0,5	15	57	S 1855-30
4,0	6,0	1,0	25	57	S 1855-40
6,0	8,0	1,0	50	41	S 1855-50
8,0	10,0	1,0	80	32	S 1855-60
10,0	12,0	1,0	130	27	S 1855-64

Applications:

- » antistatic applications
- » in explosive ambience (explosion protection)
- » for transport of highly flammable solvents or alcohols
- » for transport of highly pure chemicals and gases

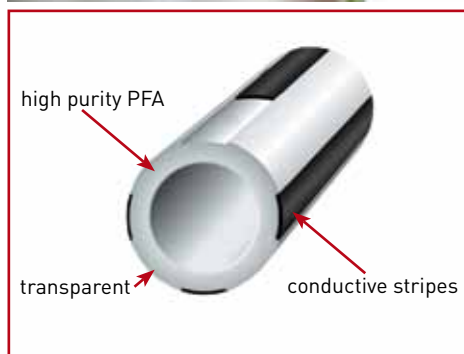

### BOLA INNOVATION

#### Zebra Tubing

Especially made for antistatic applications: Transparent tubing made of PFA with black longitudinal conductive stripes on the outer surface. Provides high chemical resistance and can be used in explosive ambience.

<sup>1</sup> Bending radius: minimum bending radius in mm at a room temperature of 23°C

<sup>2</sup> Burst pressure: computed value in bar at a room temperature of 23°C. It is recommended to restrict the maximum working pressure to 25% of the burst pressure. For higher temperatures, this value has to be multiplied by the reduction factor shown on page 244. It is the user's responsibility to check if the used tubing fulfils the respective requirements.

## BOLA PTFE Tubing

**BESTSELLER**

Material: **PTFE** Temperature resistance: **from -200°C to +260°C** Chemical resistance: **+++ universal**



Product description:  
Translucent to milky-white appearance

FDA conform

**Product advantages:**

- » almost universal chemical resistance
- » free from extractable agents
- » physiologically safe
- » non-adhesive surface
- » very good sliding characteristics
- » very good dielectric characteristics
- » biocompatibility certified according to USP class VI
- » flame retardant according to UL94V0
- » oxygen value more than 95
- » resistant to irradiation and weather
- » can be sterilized in ETO and in autoclaves



**SUITABLE:** page 98  
Fittings, screw joints,  
stopcocks, valves

I.D. mm	O.D. mm	Wall thickness mm	Bending radius <sup>1</sup> mm	Burst pressure <sup>2</sup> bar	Cat. No.:
0,2	(1/16") 1,6	0,70	6	960	S 1810-01
0,2	0,4	0,10	2	960	S 1810-02
0,3	0,6	0,15	3	140	S 1810-04
0,3	(1/16") 1,6	0,65	4	606	S 1810-05
0,4	0,9	0,25	3	175	S 1810-06
0,5	1,0	0,25	4	140	S 1810-08
0,5	(1/16") 1,6	0,55	5	308	S 1810-09
(1/32") 0,8	(1/16") 1,6	0,40	7	140	S 1810-10
1,0	(1/16") 1,6	0,30	8	84	S 1810-12
1,0	2,0	0,50	8	140	S 1810-14
1,0	3,0	1,00	9	280	S 1810-16
1,2	1,8	0,30	8	70	S 1810-18
1,4	2,2	0,40	12	80	S 1810-19
1,5	2,1	0,30	14	56	S 1810-20
1,5	2,5	0,50	13	93	S 1810-22
1,5	3,0	0,75	12	140	S 1810-23
1,5	3,5	1,00	12	186	S 1810-21
(1/16") 1,6	(1/8") 3,2	0,80	13	140	S 1810-26
(1/16") 1,6	2,4	0,40	14	70	S 1810-24
1,9	2,5	0,30	20	44	S 1810-28
2,0	3,0	0,50	18	70	S 1810-30
2,0	4,0	1,00	16	140	S 1810-32
2,4	(1/8") 3,2	0,40	25	46	S 1810-33
3,0	4,0	0,50	32	46	S 1810-34
3,0	5,0	1,00	25	93	S 1810-36
3,0	6,0	1,50	24	140	S 1810-37

You will find further tubing diameters in the adjoining chart

I.D. mm	O.D. mm	Wall thickness mm	Bending radius <sup>1</sup> mm	Burst pressure <sup>2</sup> bar	Cat. No.:
Continuation of tubing diameters					
4,0	5,0	0,50	50	35	S 1810-38
4,0	6,0	1,00	36	70	S 1810-40
(11/64") 4,35	(1/4") 6,35	1,00	40	64	S 1810-42
5,0	6,0	0,50	72	28	S 1810-44
5,0	7,0	1,00	49	56	S 1810-46
6,0	7,0	0,50	98	23	S 1810-48
6,0	8,0	1,00	64	46	S 1810-50
7,0	8,0	0,50	128	20	S 1810-52
7,0	9,0	1,00	81	40	S 1810-54
7,5	10,0	1,25	80	46	S 1810-56
8,0	(3/8") 9,52	0,75	120	26	S 1810-58
8,0	10,0	1,00	100	35	S 1810-60
8,0	11,0	1,50	80	52	S 1810-61
8,0	12,0	2,00	72	70	S 1810-62
9,0	11,0	1,00	121	31	S 1810-63
10,0	12,0	1,00	144	28	S 1810-64
10,0	14,0	2,00	98	56	S 1810-66
12,0	14,0	1,00	196	23	S 1810-68
12,0	16,0	2,00	128	46	S 1810-70
13,0	16,0	1,50	170	32	S 1810-72
14,0	16,0	1,00	256	20	S 1810-74
16,0	18,0	1,00	324	17	S 1810-78
18,0	20,0	1,00	400	16	S 1810-84
20,0	22,0	1,00	490	14	S 1810-88

**Applications:**

- » Perfect tubing for aggressive and pure liquids or gases

<sup>1</sup> Bending radius: minimum bending radius in mm at a room temperature of 23°C

<sup>2</sup> Burst pressure: computed value in bar at a room temperature of 23°C. It is recommended to restrict the maximum working pressure to 25% of the burst pressure. For higher temperatures, this value has to be multiplied by the reduction factor shown on page 244. It is the user's responsibility to check if the used tubing fulfills the respective requirements.

## BOLA FEP Tubing

Material: **FEP**      Temperature resistance: **from -270°C to +205°C**      Chemical resistance: **+++ universal**      Transparency: **transparent**

Product description:  
Transparent, gastight tubing



FDA conform

### Product advantages:

- » non-porous
- » almost universal chemical resistance
- » free from extractable agents
- » physiologically safe
- » non-adhesive surface
- » very good sliding characteristics
- » very good dielectric characteristics
- » biocompatibility certified according to USP class VI
- » flame retardant according to UL94V0
- » oxygen value more than 95
- » resistant to irradiation and weather
- » can be sterilized in Gamma, ETQ, E-Beam and in autoclaves

	I.D. mm	O.D. mm	Wall thickness mm	Bending radius <sup>1</sup>	Burst pressure <sup>2</sup> bar	Cat. No.:
	(1/32") 0,8	(1/16") 1,6	0,40	7	112	S 1815-04
	(1/16") 1,6	(1/8") 3,2	0,80	13	112	S 1815-08
	2,0	3,0	0,50	18	56	S 1815-07
	2,0	4,0	1,00	16	112	S 1815-12
	3,6	6,0	1,20	30	75	S 1815-16
	(5/32") 3,96	(1/4") 6,35	1,20	34	67	S 1815-24
	4,0	6,0	1,00	36	56	S 1815-20
	(11/64") 4,35	(1/4") 6,35	1,00	52	51	S 1815-28
	5,6	8,0	1,20	53	48	S 1815-32
	6,0	8,0	1,00	64	37	S 1815-36
	(1/4") 6,35	(3/8") 9,52	1,59	58	56	S 1815-40
	6,8	10,0	1,60	63	53	S 1815-44
	8,0	10,0	1,00	100	28	S 1815-48
	(3/8") 9,52	(1/2") 12,7	1,59	101	37	S 1815-56
	10,0	12,0	1,00	144	22	S 1815-60
	12,0	14,0	1,00	196	19	S 1815-68

### Applications:

- » Perfect tubing for aggressive and pure liquids or gases

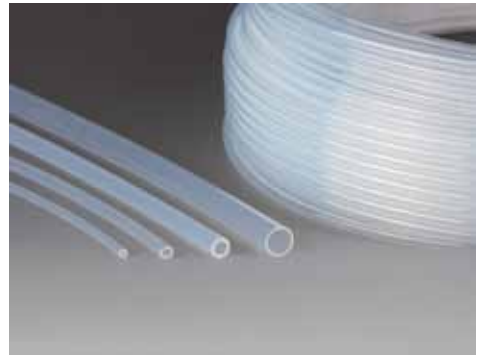

### How can you calculate the maximum bending radius?

Very easy: Squared outer diameter of tubing divided by wall thickness.



### »» PTFE and PFA Tubing

All BOLA Tubing have small tolerance on the outer diameter and the wall thickness. This assures that fittings and screw joints always match.



Inge Fenstad » Chiron AS

<sup>1</sup> Bending radius: minimum bending radius in mm at a room temperature of 23°C

<sup>2</sup> Burst pressure: computed value in bar at a room temperature of 23°C. It is recommended to restrict the maximum working pressure to 25% of the burst pressure. For higher temperatures, this value has to be multiplied by the reduction factor shown on page 244. It is the user's responsibility to check if the used tubing fulfils the respective requirements.

## BOLA PFA Tubing

Material: **PFA**    Temperature resistance: **from -200°C to +260°C**    Chemical resistance: **+++ universal**    Transparency: **transparent**

Product description:  
Transparent, gastight tubing



FDA conform

**Product advantages:**

- » non-porous
- » almost universal chemical resistance
- » free from extractable agents
- » physiologically safe
- » non-adhesive surface
- » very good sliding characteristics
- » very good dielectric characteristics
- » biocompatibility certified according to USP class VI
- » flame retardant according to UL94V0
- » oxygen value more than 95
- » resistant to irradiation and weather
- » can be sterilized in Gamma, ETO, E-Beam and in autoclaves
- » mechanical strength even at high temperatures

I.D. mm	O.D. mm	Wall thickness mm	Bending radius <sup>1</sup>	Burst pressure <sup>2</sup> bar	Cat. No.:
(1/32") 0,8	(1/6") 1,6	0,40	7	140	S 1811-02
(1/6") 1,6	(1/8") 3,2	0,80	13	140	S 1811-04
2,0	3,0	0,50	18	70	S 1811-05
2,0	4,0	1,00	16	140	S 1811-06
3,6	6,0	1,20	30	96	S 1811-08
(5/32") 3,96	(1/4") 6,35	1,20	34	84	S 1811-12
4,0	6,0	1,00	36	70	S 1811-10
(11/64") 4,35	(3/8") 6,35	1,00	52	64	S 1811-14
5,6	8,0	1,20	53	60	S 1811-16
6,0	8,0	1,00	64	46	S 1811-18
6,35	9,52	1,59	58	70	S 1811-20
6,8	10,0	1,60	63	66	S 1811-22
8,0	10,0	1,00	100	35	S 1811-24
8,8	12,0	1,60	90	51	S 1811-26
(3/8") 9,52	(1/2") 12,7	1,59	101	47	S 1811-28
10,0	12,0	1,00	144	28	S 1811-30
12,0	14,0	1,00	196	23	S 1811-40
14,0	16,0	1,00	256	20	S 1811-50

**Applications:**

- » Perfect tubing for aggressive and pure liquids or gases

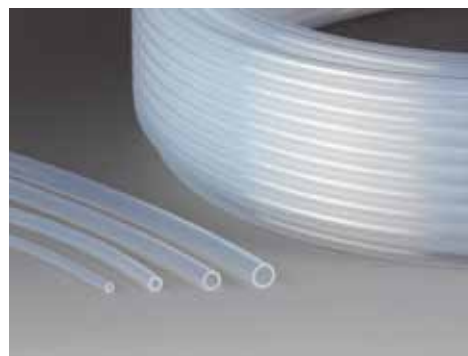

### BOLA INNOVATION

**Perfect connection**

Tubing with industrial standards have a very big range of tolerance. This can lead to problems regarding connection. BOLA Tubing is exactly suited to the strict BOLA standard.

<sup>1</sup> Bending radius: minimum bending radius in mm at a room temperature of 23°C

<sup>2</sup> Burst pressure: computed value in bar at a room temperature of 23°C. It is recommended to restrict the maximum working pressure to 25% of the burst pressure. For higher temperatures, this value has to be multiplied by the reduction factor shown on page 244. It is the user's responsibility to check if the used tubing fulfills the respective requirements.

## BOLA PFA Corrugated Tubing

Material: <b>PFA</b>	Temperature resistance: <b>from -270°C to +260°C</b>	Chemical resistance: <b>+++ universal</b>	Transparency: <b>transparent</b>	Vacuum: <b>suitable</b>
-------------------------	---	--	-------------------------------------	----------------------------

Product description:

Circular corrugations around the longitudinal axis. Can be shortened easily by means of a tubing cutter (see page 141).

FDA conform

Nominal width NW	I.D. A mm	O.D. B mm	Bending radius <sup>1</sup> C mm	Pressure load max. bar	Cat. No.:
4,5	4,3	6,8	5	1,7	S 1820-01
8	7,7	10,7	15	3,4	S 1820-02
10	9,7	13,0	18	2,8	S 1820-04
13	12,4	16,1	23	2,6	S 1820-06
14	13,7	17,8	25	2,3	S 1820-08
16	15,4	19,7	28	2,3	S 1820-10
19	18,4	23,2	32	2,2	S 1820-14
21	19,8	24,8	35	2,1	S 1820-16
23	23,8	28,8	40	1,2	S 1820-23

### Product advantages:

- » flexible to highly flexible
- » tight bending radius only causes little cross-section reduction
- » non-porous
- » translucent
- » resistant to irradiation and weather
- » almost universal chemical resistance

### Applications:

- » Perfect tubing for aggressive and pure liquids or gases

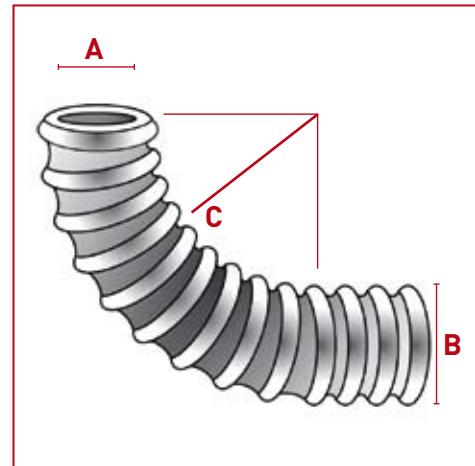

## BOLA Colour Tubing

Material: <b>PTFE</b>	Temperature resistance: <b>from -200°C to +260°C</b>	Chemical resistance: <b>+++ universal</b>
--------------------------	---	--

Product description:

This completely imbued tubing is lightfast, different colours assure high safety against confusions. The colour pigments can possibly affect the chemical resistance.

I.D. mm	O.D. mm	Bending radius <sup>1</sup> mm	Colour	Cat. No.:
4	6	36	red	S 1861-40
6	8	64	red	S 1861-50
4	6	36	blue	S 1862-40
6	8	64	blue	S 1862-50
4	6	36	green	S 1863-40
6	8	64	green	S 1863-50
4	6	36	yellow	S 1864-40
6	8	64	yellow	S 1864-50



<sup>1</sup> Bending radius: minimum bending radius in mm at a room temperature of 23°C

## BOLA Heat Shrinkable Tubing

Material: <b>PTFE</b>	Temperature resistance: <b>from -270°C to +260°C</b>	Chemical resistance: <b>+++ universal</b>	Transparency: <b>transparent</b>	Shrink rate: <b>4:1</b>
--------------------------	---	--	-------------------------------------	----------------------------

### Product description:

For protection of probes, cables, electric components etc. against chemical disturbance. The shrink rate of 4:1 means that the inner diameter of the tubing shrinks to approx. 1/4 of the original inner diameter and that the length shrinks to approx. 15%. Good heat transmission due to low wall thickness.

FDA conform

Expanded I.D. mm	Min. shrunk O.D. mm	Wall thickness after shrinkage mm	Cat. No.:
(5/64") 2,0	0,7	0,22	<b>S 1828-08</b>
(1/8") 3,2	1,0	0,25	<b>S 1828-16</b>
(3/16") 4,7	1,3	0,30	<b>S 1828-24</b>
(1/4") 6,3	(1/16") 1,6	0,30	<b>S 1828-32</b>
(8/8") 9,5	2,5	0,30	<b>S 1828-40</b>
(1/2") 12,7	3,7	0,38	<b>S 1828-48</b>
(3/4") 19,0	5,7	0,38	<b>S 1828-56</b>
(1") 25,4	7,0	0,38	<b>S 1828-64</b>

### Product advantages:

- » transparent
- » incombustible (ASTM D876)
- » insulation resistance  $10^{18} \Omega/\text{cm}$  (ASTM D 876)
- » good electric strength
- » flame retardant



**HELPFUL:** page 248  
Detailed instructions  
for processing

## BOLA Spiral Tubing

Material: <b>PFA</b>	Temperature resistance: <b>from -270°C to +260°C</b>	Chemical resistance: <b>+++ universal</b>	Transparency: <b>transparent</b>
-------------------------	---	--	-------------------------------------

### Product description:

Spiral tubing made of PFA is manufactured individually according to your specifications. Please take the possible tubing dimensions from the list on page 138. We would be glad to send you a quotation.

**Please complete the list below and send us a copy by fax to +49 (0)9346-928651. Thank you.**

FDA conform

Quantity:	
<b>A</b> Tubing I.D.:	
<b>B</b> Tubing O.D.:	
<b>C</b> Spiral I.D.:	
<b>D</b> Spiral O.D.:	
<b>E</b> Length of tubing ends:	
<b>F</b> Length of spiral:	

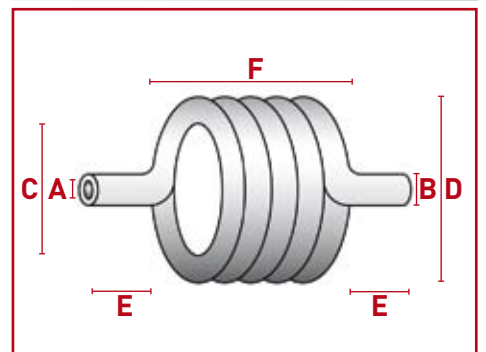
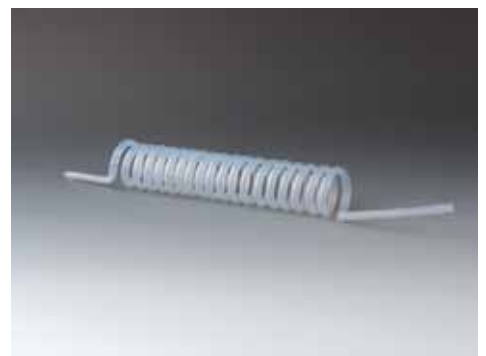

## BOLA Tubing Cutter

Product description:

Ideal for cutting plastic and rubber tubing with and without textile reinforcement up to a diameter of 28 mm. The blade is exchangeable.  
Not suitable for steel reinforced tubing.

Up to tubing O.D. max. mm	Cat. No.:
28	S 1852-28



## BOLA Replacement Blades

Product description:

For tubing cutter S 1852-28.

Up to tubing O.D. max. mm	Cat. No.:
28	S 1853-28



## BOLA PEEK Capillary Tubing

Material: PEEK      Temperature resistance: from -50°C to +250°C      Chemical resistance: +++ universal

Product description:

Flexible, brown high-pressure tubing for almost all organic or inorganic liquids.

FDA conform

I.D. mm	O.D. mm	Bending radius mm	Pressure resistant up to bar	Cat. No.:
0,25	(1/16") 1,6	4	350	S 1817-08
0,50	(1/16") 1,6	4	350	S 1817-12
(1/32") 0,80	(1/16") 1,6	4	280	S 1817-16
(1/16") 1,60	(1/8") 3,2	7	280	S 1817-20

Product advantages:

- » metal-free
- » corrosion-proof
- » high pressure resistance
- » biocompatible
- » high temperature resistance (melting point +334°C)
- » alternative for capillary tubing made of titan or stainless steel



## BOLA Assortment of Remainder Tubing

Material: PTFE      Material: PFA      Material: FEP      Temperature resistance: from -200°C to +250°C      Chemical resistance: +++ universal

Product description:

No rejections. Approx. 10 rolls of unsorted tubing made of PTFE, FEP and PFA with different diameters. Length of up to 2 metres per roll. No selection possible.

FDA conform

Cat. No.:
S 1899-10



## BOLA Tiles

Material: PTFE      Temperature resistance: from -200°C to +250°C      Chemical resistance: +++ universal

Product description:  
Standard sizes with different thicknesses

FDA conform

Length x width x height mm			Cat. No.:
300 x 300 x 2			S 1805-02
300 x 300 x 3			S 1805-04
300 x 300 x 4			S 1805-06
300 x 300 x 5			S 1805-08
300 x 300 x 6			S 1805-10
300 x 300 x 8			S 1805-12
300 x 300 x 10			S 1805-14
300 x 300 x 15			S 1805-16

### Applications:

Ideal for using as table pad. Also suitable for using as slideway or for insulation.



## BOLA Sheets

**BESTSELLER**

Material: PTFE      Temperature resistance: from -200°C to +250°C      Chemical resistance: +++ universal

Product description:  
Delivered in rolls with a length of 1000 mm. Colour: white

FDA conform

Thickness mm	Cat. No.: width 300 mm	Cat. No.: width 600 mm
0,05	S 1803-02	S 1803-21
0,12	S 1803-04	S 1803-23
0,25	S 1803-06	S 1803-25
0,50	S 1803-08	S 1803-27
0,75	S 1803-10	S 1803-29
1,00	S 1803-12	S 1803-31
1,50	S 1803-14	S 1803-33

### Applications:

Ideal for using as table pad or for lining drawers. Also suitable for using as slideway or for insulation.





## BOLA FEP Sheets

Material: **FEP**      Temperature resistance: **from -200°C to +250°C**      Chemical resistance: **+++ universal**

Product description:

Transparent, gastight and non-porous rolls with a length of 1000 mm.

FDA conform

Thickness mm	Width mm	Length mm	Cat. No.:
0,025	150	1000	S 1833-04
0,05	150	1000	S 1833-08
0,25	150	1000	S 1833-16
0,025	300	1000	S 1833-34
0,05	300	1000	S 1833-38
0,25	300	1000	S 1833-46

### Applications:

Ideal for using as table pad or for lining drawers. Also suitable for using as slideway or for insulation.



## BOLA Rods

Material: **PTFE**      Temperature resistance: **from -200°C to +250°C**      Chemical resistance: **+++ universal**

Product description:

Virginal rods for further treatment and processing in lengths of up to 2 m. Diameter and length are nominal dimensions and can contain a machining allowance.

FDA conform

O.D. mm	Cat. No.:
6	S 1800-06
8	S 1800-08
10	S 1800-10
12	S 1800-12
15	S 1800-15
16	S 1800-16
20	S 1800-20
25	S 1800-25
30	S 1800-30
35	S 1800-35
40	S 1800-40
50	S 1800-50
65	S 1800-65



## BOLA Sealing Tape

Material: **PTFE**      Temperature resistance: **from -200°C to +250°C**      Chemical resistance: **+++ universal**

Product description:

For sealing threads, checked according to DIN / DVGW and KTW.

FDA conform

Width mm	Thickness mm	Length mtr.	Cat. No.:
12	0,1	12	H 960-01

**Product advantages:**

- » does not embrittle, swell and agglutinate
- » does not contain oil or grease
- » prevents rusting and sticking
- » easy removal even after years



## BOLA Flat Sealing Tapes

Material: **PTFE**      Temperature resistance: **from -200°C to +270°C**      Chemical resistance: **+++ universal**

Product description:

Deformable, virginal PTFE flat tape with expanded fibre structure.

**NEW**

FDA conform

Thickness mm	Width mm	Length mtr.	Cat. No.:
5	2	20	H 959-16
10	3	10	H 959-22
14	4	10	H 959-28
22	7	5	H 959-34
30	5	5	H 959-40
50	5	5	H 959-50

**Product advantages:**

- » tasteless
- » odourless up to +270°C
- » self-adhesive
- » physiologically safe
- » not ageing
- » good sealing also on uneven surfaces
- » almost universal chemical resistance
- » quick and easy assembly

**Applications:**

For making customized gaskets "on-site".



## BOLA Fluoroplastic Spray

Material:  
PTFE

Product description:  
Release and anti-blocking agent as well as lubricant for laboratory,

FDA conform

Capacity ml	Cat. No.:
400	H 958-04

**Product advantages:**

- » dry and greaseless
- » CFC and silicone-free
- » heat resistant up to +260°C
- » non-adhesive and dirt-repellent
- » physiologically safe
- » excellent gliding and separating effects



## BOLA Fluorslidepaste

Material: PTFE  
Temperature resistance: from -36°C to +260°C  
Chemical resistance: +++ universal

Product description:  
Extremely stable, synthetic high-temperature paste in resealable tube.

FDA conform

Capacity g	Cat. No.:
56	S 1870-16

**Product advantages:**

- » exceptionally low friction coefficient
- » extremely long-lasting
- » for temperatures between -36°C and over +260°C
- » resists high mechanical loads
- » not soluble in most solvents
- » non-flammable
- » oxygen-resistant
- » compatible with all common elastomers and plastics
- » chemical resistance against aggressive chemicals or solvents



## BOLA Fluoroplastic Grease Tubes

Material: PTFE  
Temperature resistance: from -20 °C to +260 °C  
Chemical resistance: +++ universal

Product description:  
High-performance grease for all kinds of greasing points, fine PTFE particles lower the friction between the surfaces, a special additive system provides extremely high pressure and temperature resistance, also suitable as anticorrosive, does not contain any heavy metals.

NEW

Capacity g	Cat. No.:
100	S 1872-16

**Product advantages:**

- » very low friction coefficient
- » extremely high pressure and temperature resistance



## BOLA Fluoroplastic Sealing Paste

Material: PTFE      Temperature resistance: from -240 °C to +260 °C      Chemical resistance: +++ universal

**Product description:**

Odourless and nontoxic paste for all kinds of sealings, non-hardening, eliminates leaks on threads even if high pressure resistance is needed, threaded connections can easily be closed and opened, the threads are prevented from being damaged.

**NEW**

Capacity g	Cat. No.:
500	S 1874-16

**Product advantages:**

- » no dropping or flowing during use
- » resealable can including brush

**Applications:**

Suitable for many bases and acids, any kinds of solvents or gases including hydrogen, ammoniac, chlorine, propane, butane, nitrogen, as well as for air, steam, refrigerants, salt water, and fuels (do not use on liquid or gaseous oxygen and lactic acid).



## BOLA Screws with Countersunk Head

Material: PTFE      Temperature resistance: from -200°C to +250°C      Chemical resistance: +++ universal

**Product description:**

Similar to DIN 963/DIN EN ISO 2009

**NEW**

FDA conform

Thread M	Pitch mm	Usable length mm	Dia. of head mm	Cat. No.:
4	0,7	30	8,4	H 1124-14
5	0,8	30	9,3	H 1124-18
6	1,0	30	11,3	H 1124-22
8	1,25	40	15,8	H 1124-26
10	1,50	40	18,3	H 1124-30

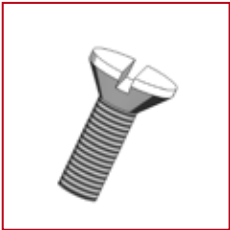

## BOLA Screws with Cylindrical Head

Material: PTFE      Temperature resistance: from -200°C to +250°C      Chemical resistance: +++ universal

**Product description:**

Similar to DIN 84/DIN EN ISO 1207

**NEW**

FDA conform

Thread M	Pitch mm	Usable length mm	Dia. of head x Height of head mm	Cat. No.:
4	0,7	30	7,0 x 4,0	H 1128-14
5	0,8	30	8,5 x 4,5	H 1128-18
6	1,0	30	10,0 x 5,0	H 1128-22
8	1,25	40	13,0 x 6,0	H 1128-26
10	1,50	40	16,0 x 7,0	H 1128-30



« »  
Special Request?  
+49 (0) 93 46-92 86-0

## BOLA Hexagon Nuts

Material: PTFE Temperature resistance: from -200°C to +250°C Chemical resistance: +++ universal

Product description:  
Similar to DIN 934 / DIN EN ISO 4032

**NEW**

FDA conform

Thread M	Pitch mm	Hexagon mm	Height mm	Cat. No.:
4	0,7	7	5,0	H 1132-14
5	0,8	8	6,0	H 1132-18
6	1,0	10	7,5	H 1132-22
8	1,25	13	9,0	H 1132-26
10	1,50	16	11,0	H 1132-30



## BOLA Washers

Material: PTFE Temperature resistance: from -200°C to +250°C Chemical resistance: +++ universal

Product description:  
Similar to DIN 125-1, packing unit: 10 pieces

**NEW**

FDA conform

Thread M	O.D. mm	I.D. mm	Height mm	Cat. No.:
4	9,0	4,3	0,9	H 1126-14
5	10,0	5,3	1,1	H 1126-18
6	12,0	6,4	1,8	H 1126-22
8	16,0	8,4	1,8	H 1126-26
10	20,0	10,5	2,2	H 1126-30



## BOLA Balls

Material: PTFE Temperature resistance: from -200°C to +250°C Chemical resistance: +++ universal

Product description:  
Made of solid PTFE, with smooth surface. Different packing units.

FDA conform

Dia. of ball mm	Packing unit	Cat. No.:
3	pack of 100 pieces	H 964-03
6	pack of 100 pieces	H 964-06
9	pack of 100 pieces	H 964-09
12	pack of 100 pieces	H 964-12
15	pack of 50 pieces	H 964-15
20	pack of 50 pieces	H 964-18
25	pack of 25 pieces	H 964-21
30	pack of 25 pieces	H 964-24

**Applications:**

For extension of surfaces of e. g. distillation apparatus;  
as splash guard



## BOLA Boiling Stones

Material: PTFE  
Temperature resistance: from -200°C to +250°C  
Chemical resistance: +++ universal

Product description:  
Prevent splashes and production of bubbles during boiling.  
Packed in resealable bag.

FDA conform

Grain size mm	Packing unit g	Cat. No.:
4	500	H 972-02
6	500	H 972-04

**Product advantages:**

- » durable
- » almost universal chemical resistance

